

K160

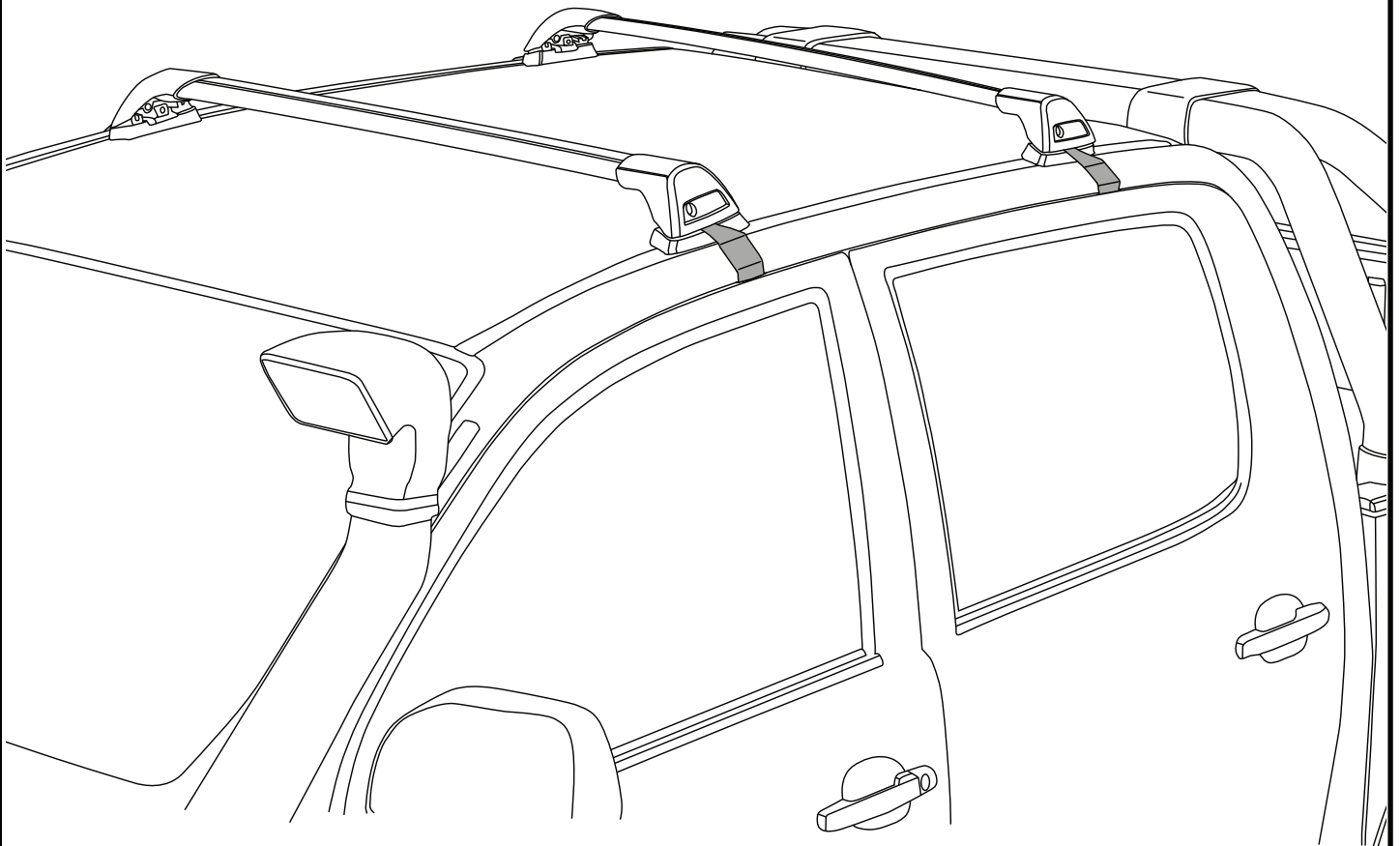

Fitting Kit



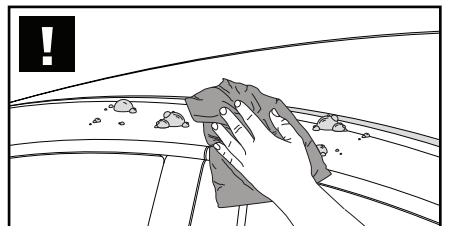
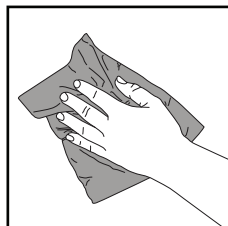
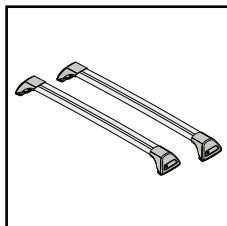
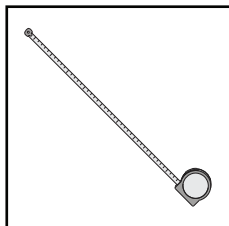
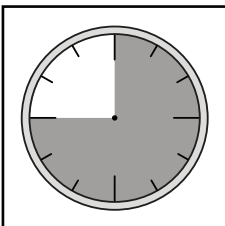

**REQUIRED • ERFORDERLICH • REQUERIDOS • OBLIGATOIRE • NØDVENDIG • NECESSÁRIO • ОБЯЗАТЕЛЬНО • OBBLIGATORIO
POTRZEBY • NEVYHNUTELNÉ • NEVYHNUTNÉ • NODIG • NÖDVÄNDIG • PÅKRÆVET • ПОТРІБНА • EDELLYTETÄÄN**

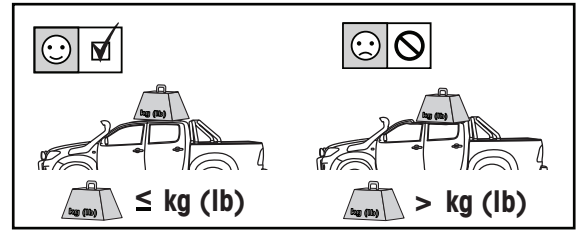
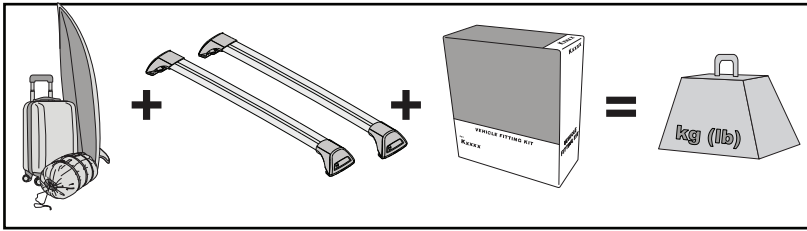

MAXIMUM kg (lb) • MAXIMUM kg • MÁXIMO kg • MAXIMUM kg • MAKSIMALT kg • MÁXIMO kg
МАКСИМУМ кг • MASSIMO kg • MAKSYMALNEJ kg • MAXIMÁLNÍ kg • MAXIMÁLNE kg
MAXIMUM kg • MAXIMAL kg • MAKSIMAL kg • МАКСИМАЛЬНА kg • ENIMMÄISMÄÄRÄ kg

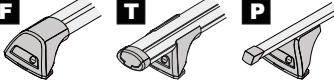
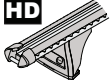

			
Toyota Hilux Single Cab, 2dr Ute 05-11	EU, CN, ZA	25 kg (55 lb)	25 kg (55 lb)
Toyota Hilux Single Cab, 2dr Ute May 05-11	AU, NZ	25 kg (55 lb)	25 kg (55 lb)
Toyota Hilux Xtra Cab, 2dr Ute 04+	EU, CN	75 kg (165 lb)	75 kg (165 lb)
Toyota Hilux Xtra Cab, 2dr Ute May 05-Oct 15	AU, NZ	75 kg (165 lb)	75 kg (165 lb)

**CONTENTS • INHALT • CONTENIDO • CONTENU • INNHOLD • CONTEÚDO • СОДЕРЖАНИЕ • CONTENUTO
ZAWARTOŚĆ • OBSAH • OBSAH • INHOUD • INNEHÅLL • INDHOLD • ЗМІСТ • SISÄLLYS**

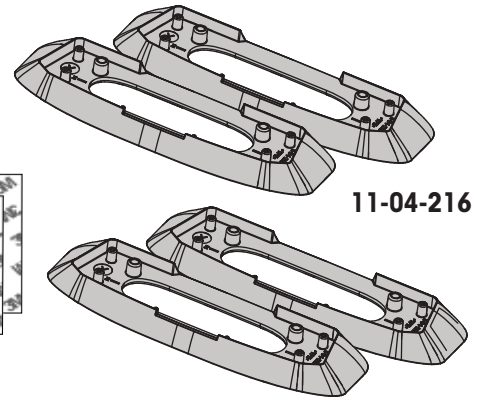
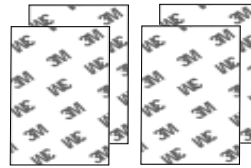
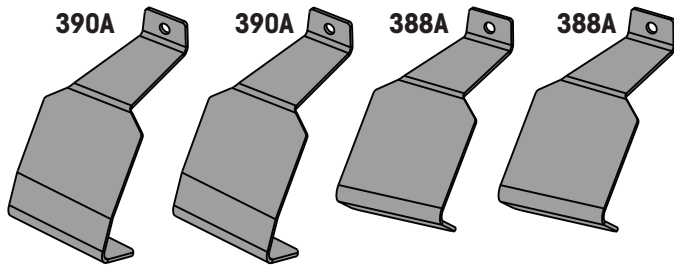

11-04-216

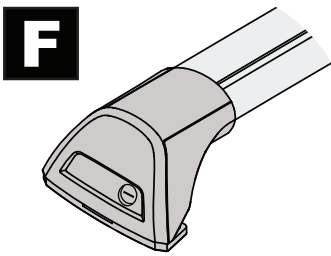

FLUSH BAR (F)

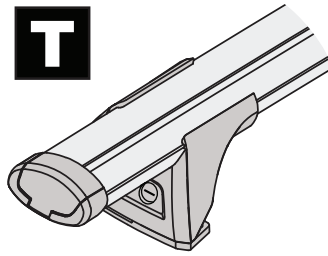

THROUGH BAR (T)

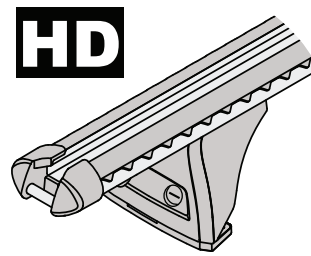

HEAVY DUTY BAR (HD)

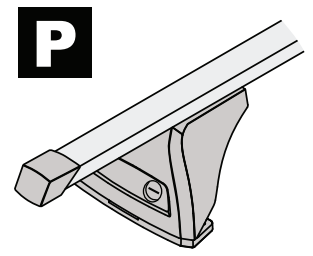

P BAR (P)

**ATTENTION • ACHTUNG • ATENCIÓN • ATTENTION • OPPMERKSOMHET • ATENÇÃO • ВНИМАНИЕ • ATTENZIONE
UWAGA • UPOZORNĚNÍ • UPOZORNENIE • LET OP • UPPMÄRKSAMHET • OPMÆRKSOMHED • УВАГА • HUOMIO**

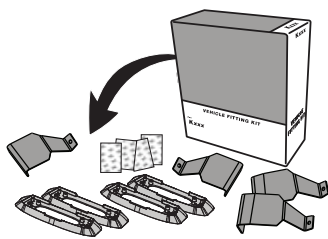

K160
= 1.0 kg (2.2 lb)

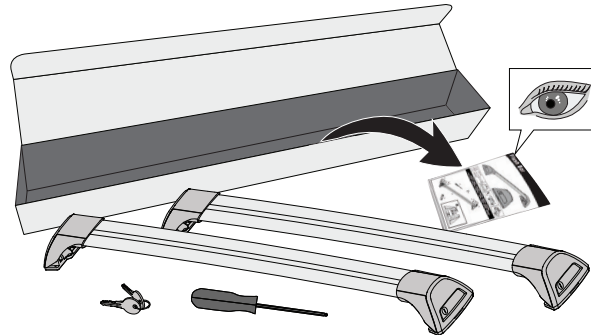

F T HD P
= kg (lb)

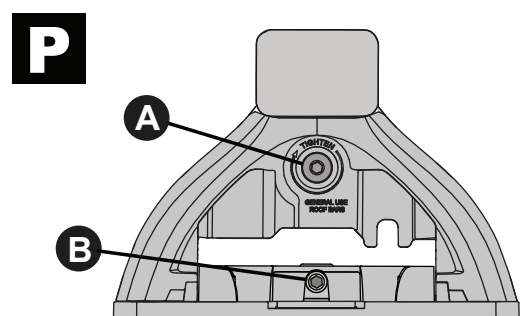
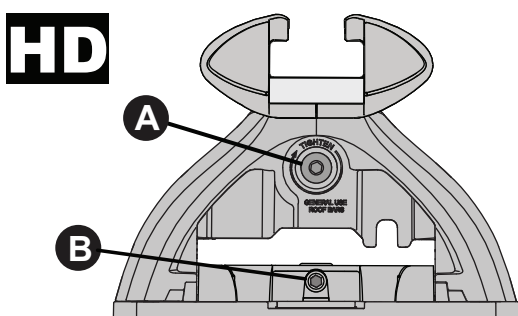
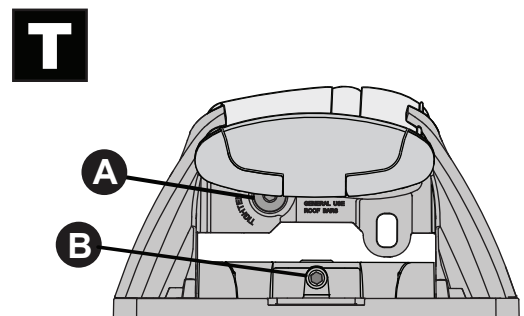
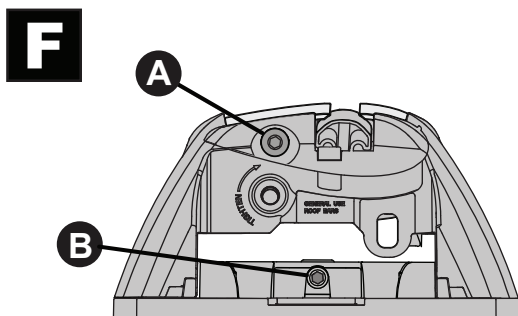

ATTENTION • ACHTUNG • ATENCIÓN • ATTENTION • OPPMERKSOMHET • ATENÇÃO • ВНИМАНИЕ • ATTENZIONE
 UWAGA • UPOZORNĚNÍ • UPOZORNENIE • LET OP • UPPMÄRKSAMHET • OPMÆRKSOMHED • УВАГА • HUOMIO

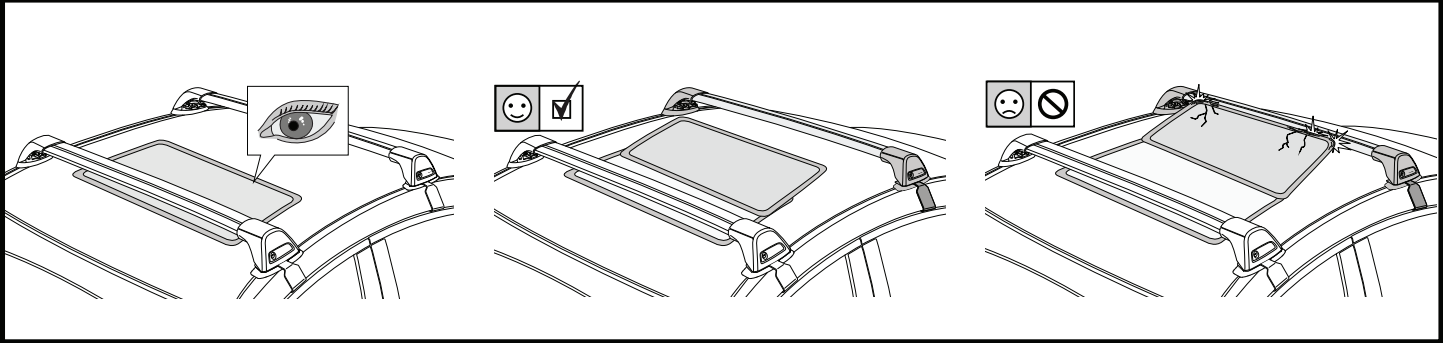

1

F

T

HD

P

x4

2

HD/P

F/T

F

T

HD

P

x10

x4

3

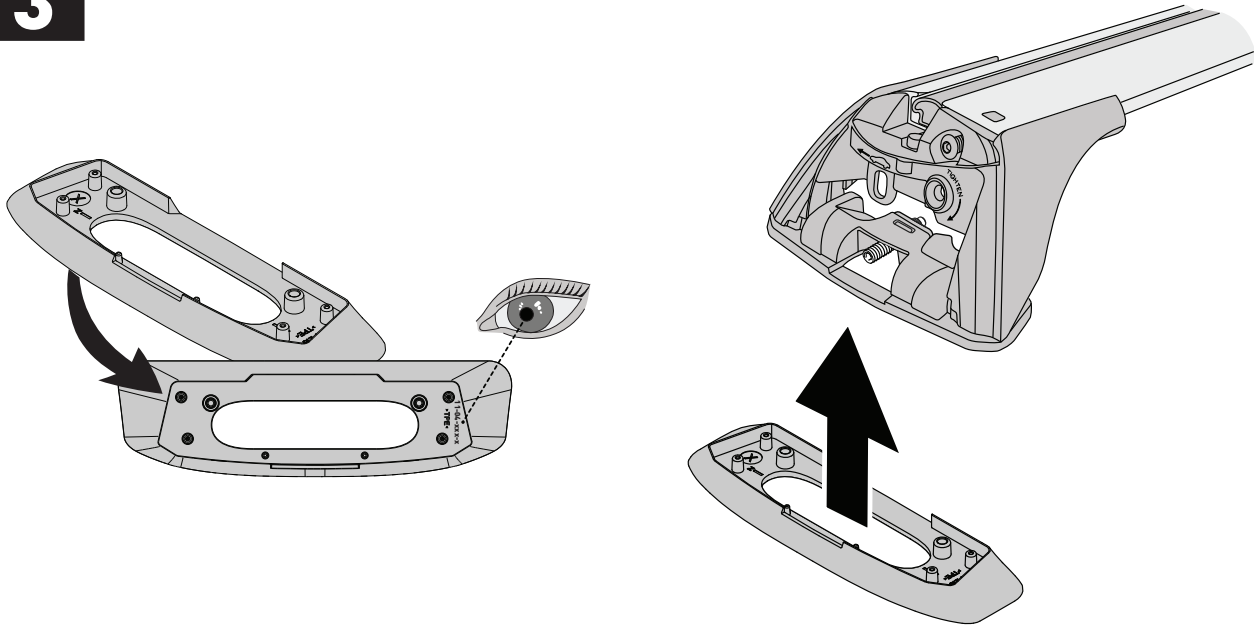

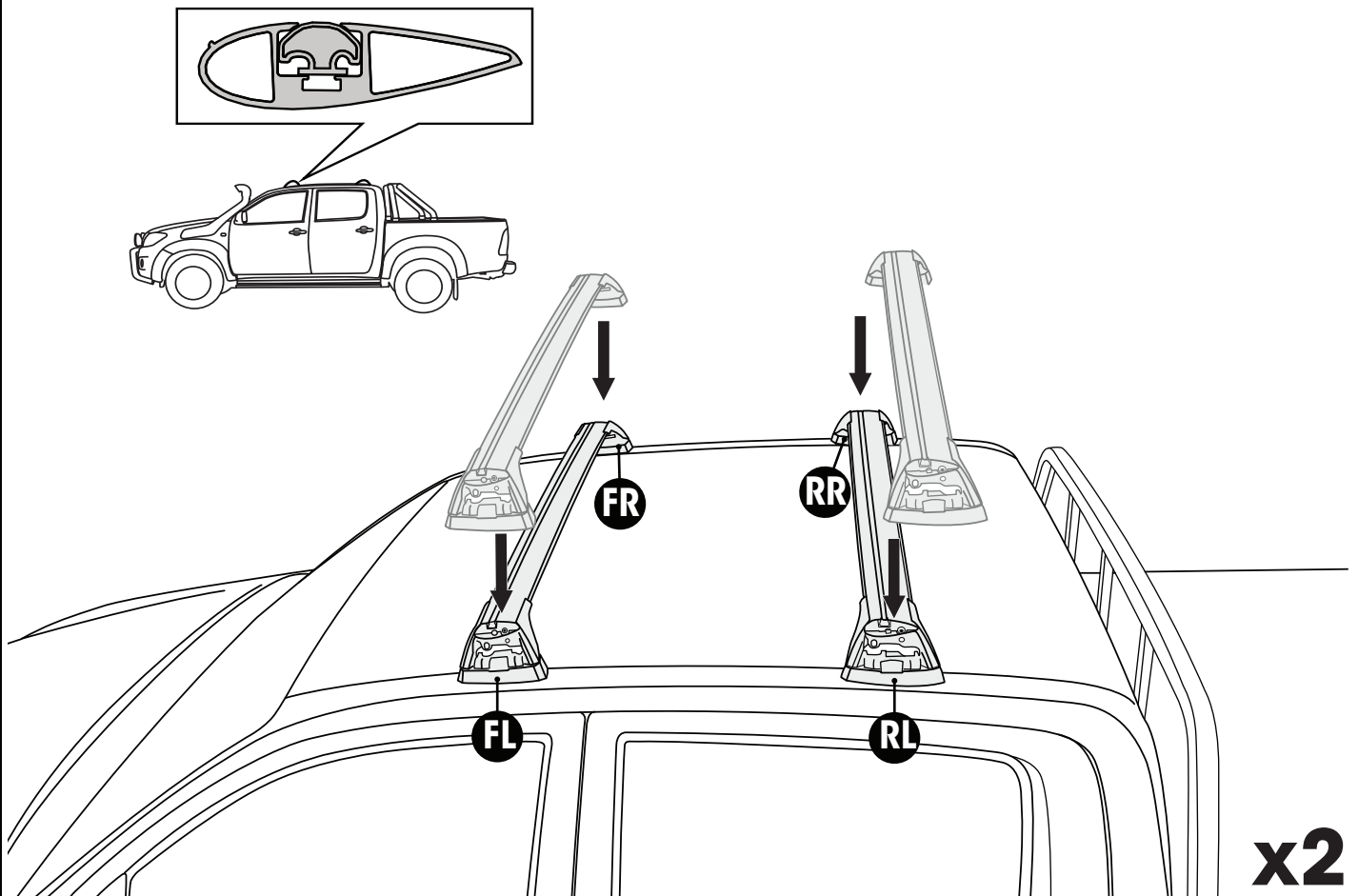

4

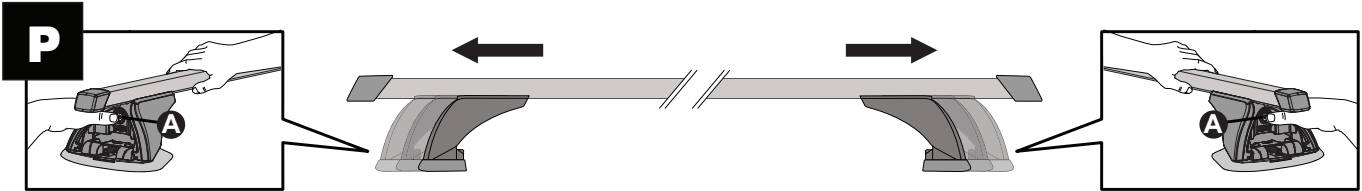
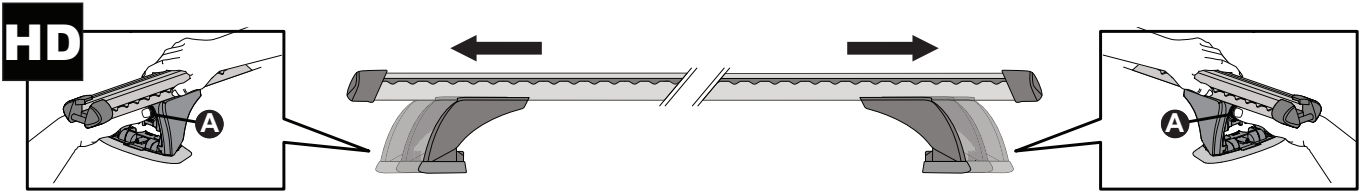
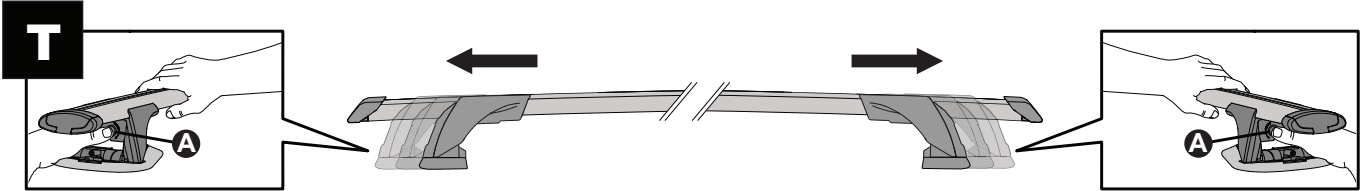
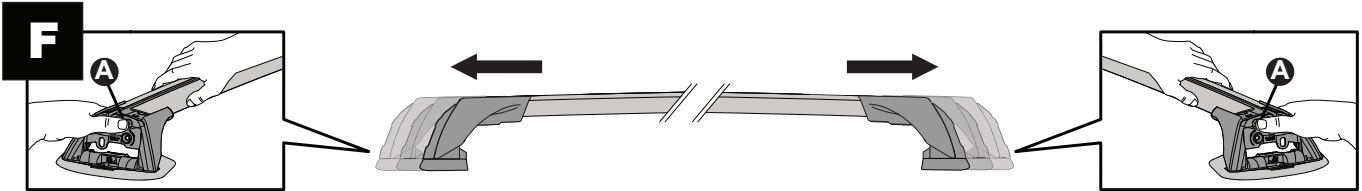
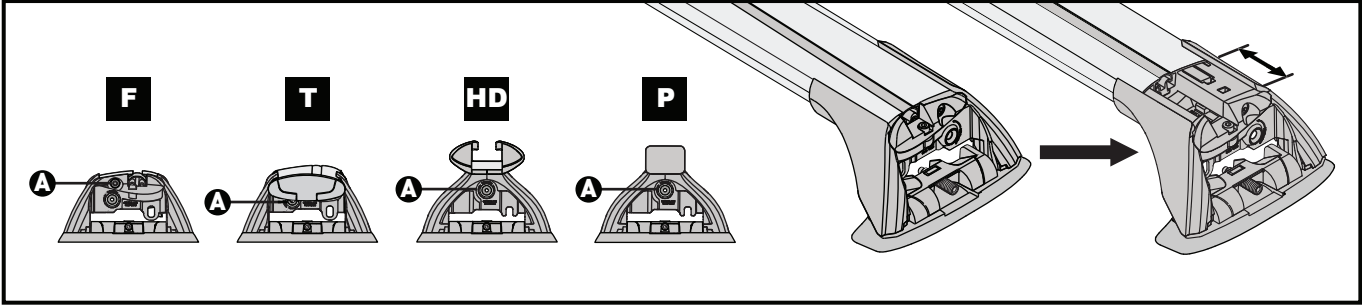

5

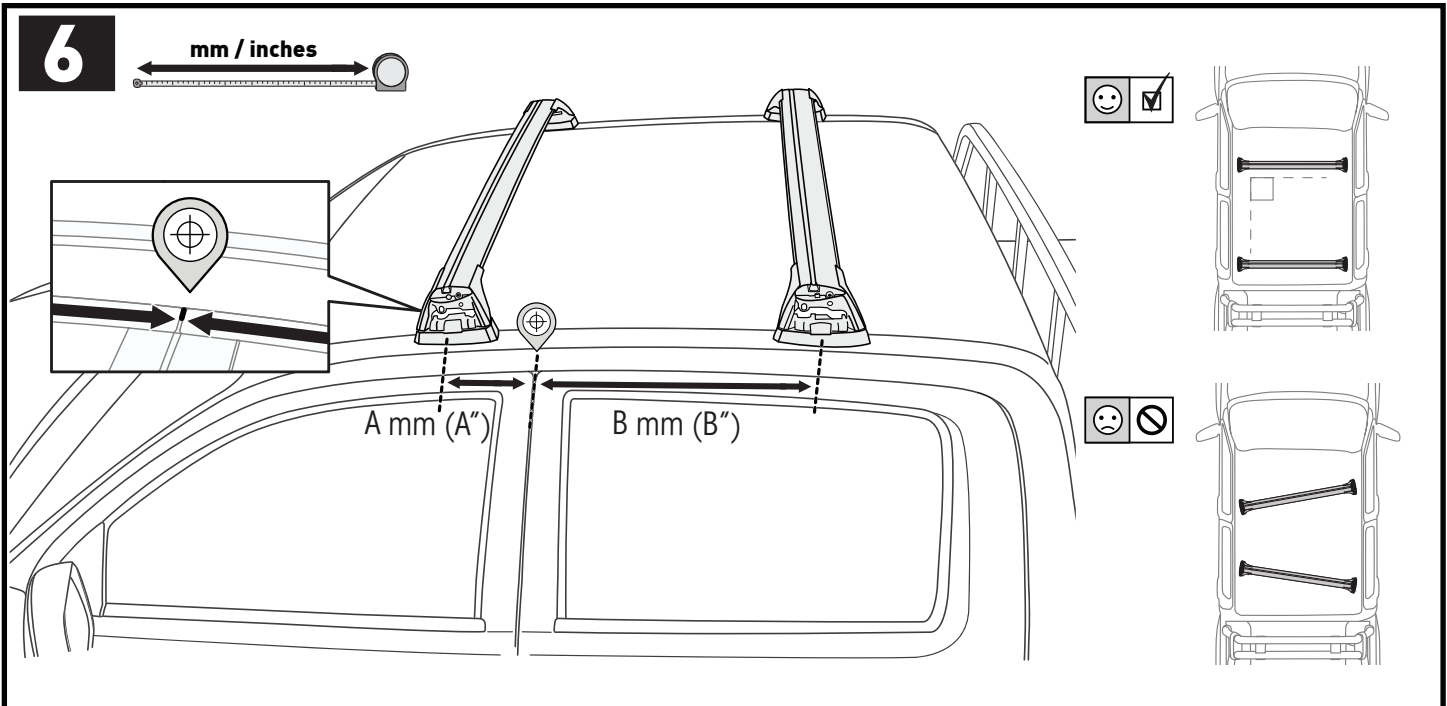



		A	B
Toyota Hilux Single Cab, 2dr Ute 05-11	EU, CN, ZA	A = 400 mm (15 3/4")	-
Toyota Hilux Single Cab, 2dr Ute May 05-11	AU, NZ	A = 400 mm (15 3/4")	-
Toyota Hilux Xtra Cab, 2dr Ute 04+	EU, CN	A = 400 mm (15 3/4")	250 mm (9 7/8")
Toyota Hilux Xtra Cab, 2dr Ute May 05-Oct 15	AU, NZ	A = 400 mm (15 3/4")	250 mm (9 7/8")

**PLACEMENT • PLATZIERUNG • COLOCACIÓN • MONTAGE • PLASSERING • COLOCAÇÃO • РАЗМЕЩЕНИЕ • MONTAGGIO
UMIESZCZENIE • UMÍSTĚNÍ • UMIESTNENIE • PLAATSING • PLACERING • PLACERING • РОЗМІЩЕННЯ • SIJOITTA**

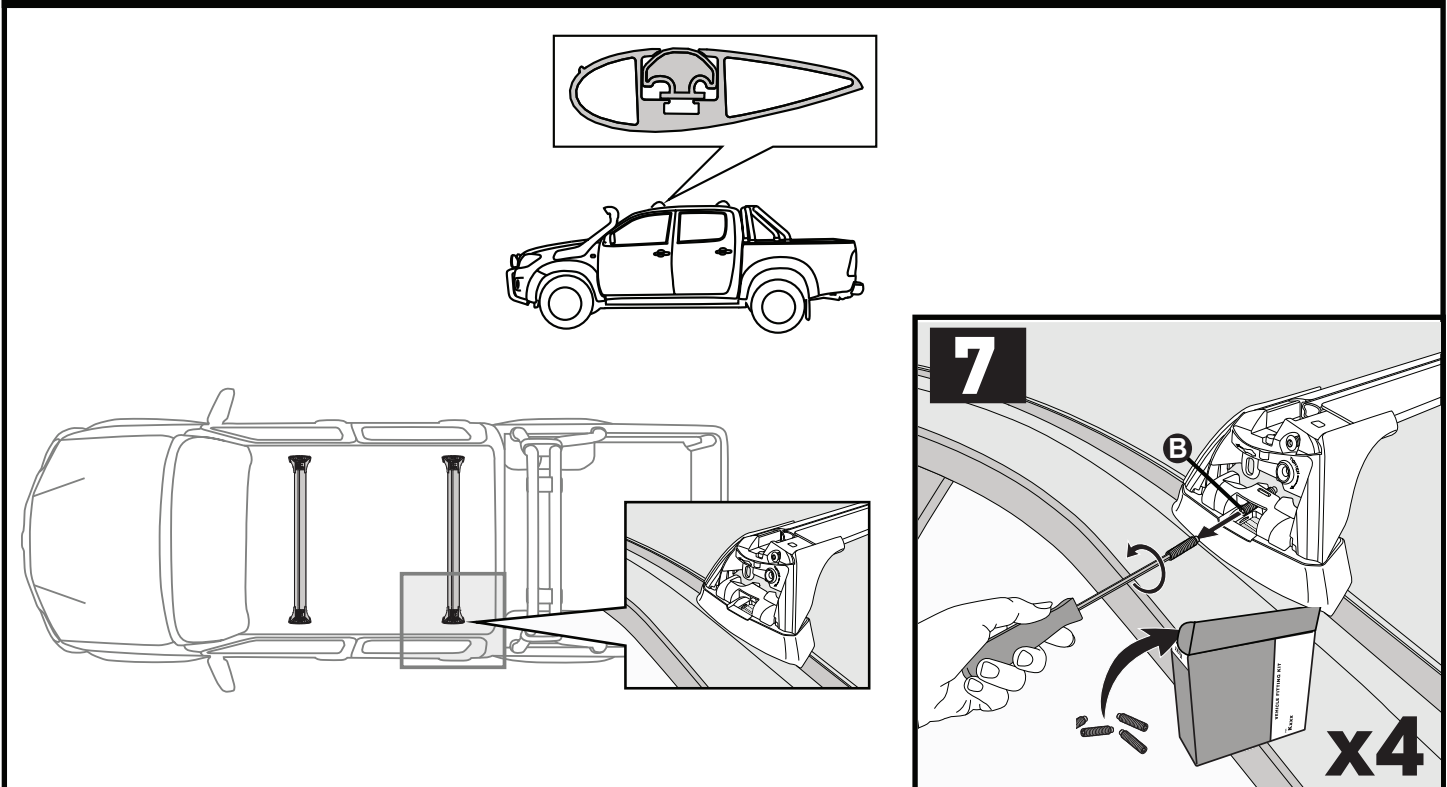

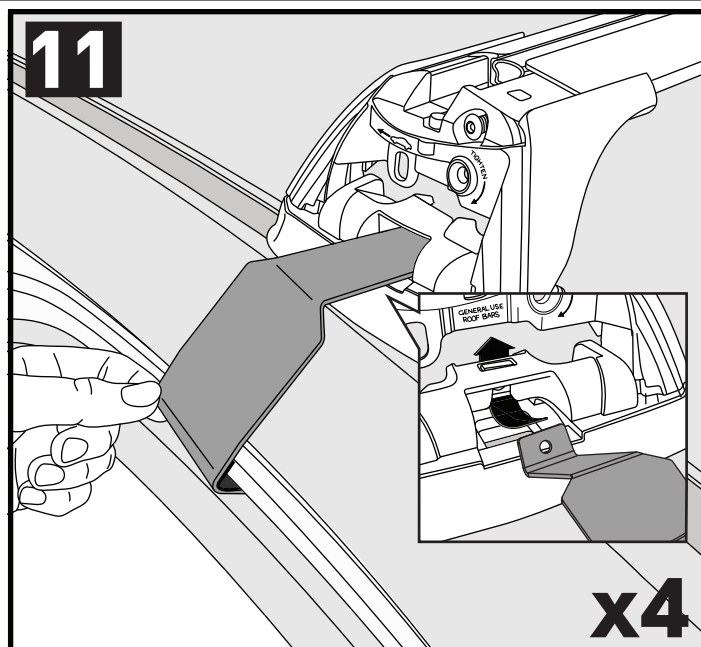
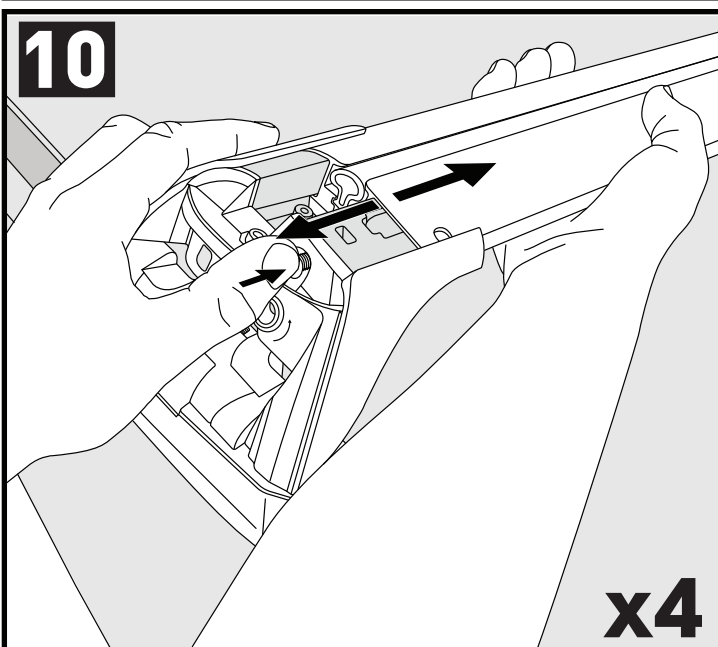
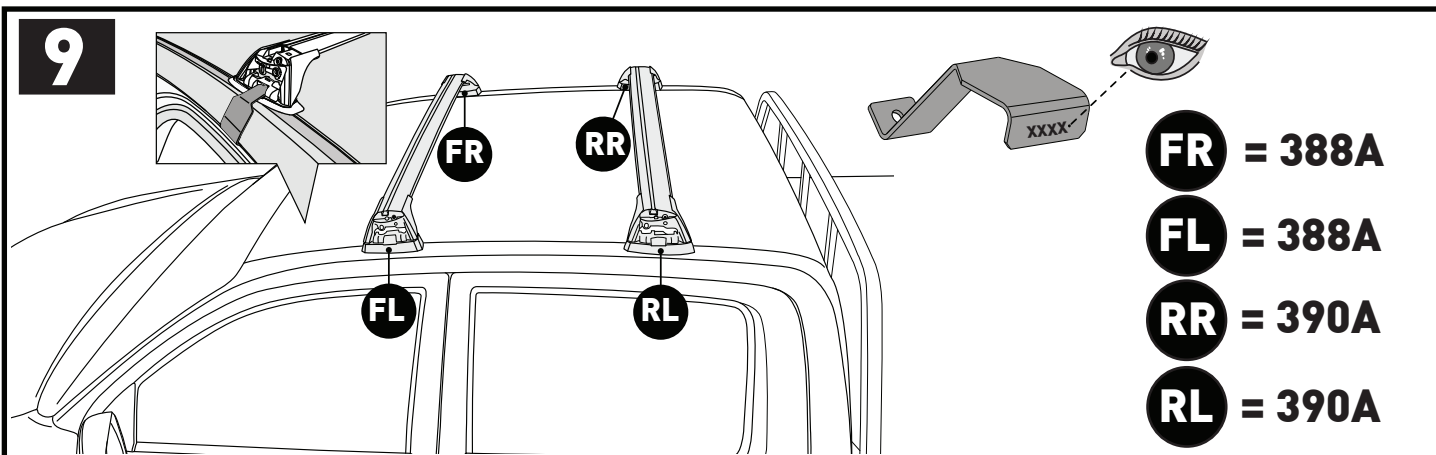
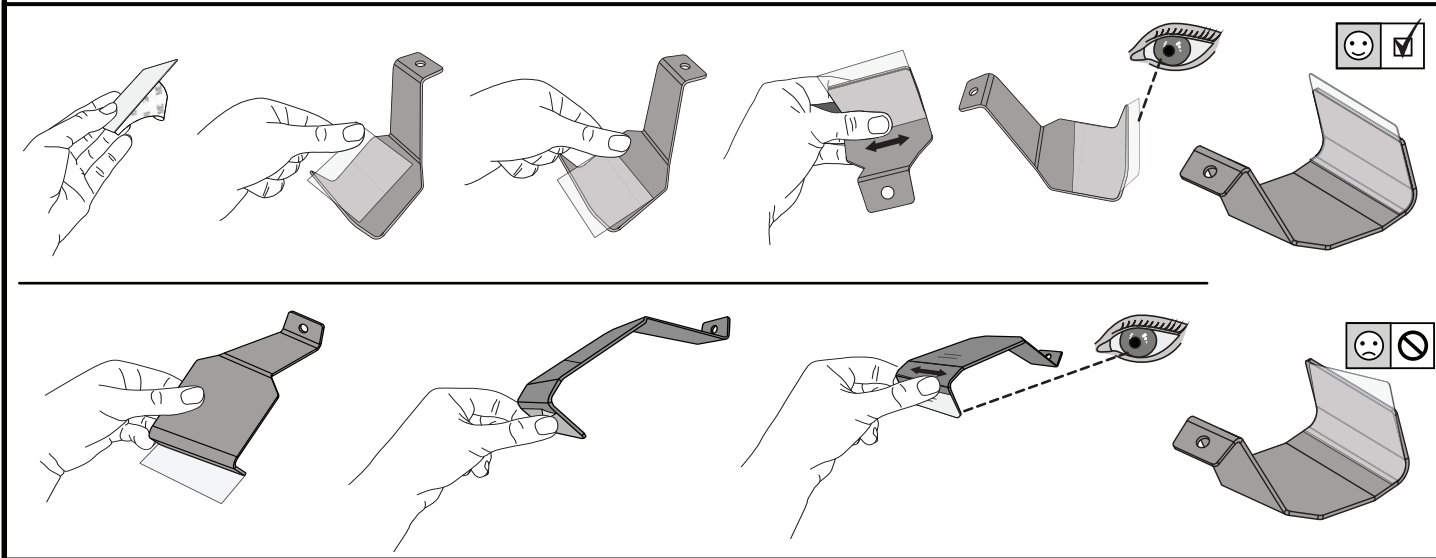

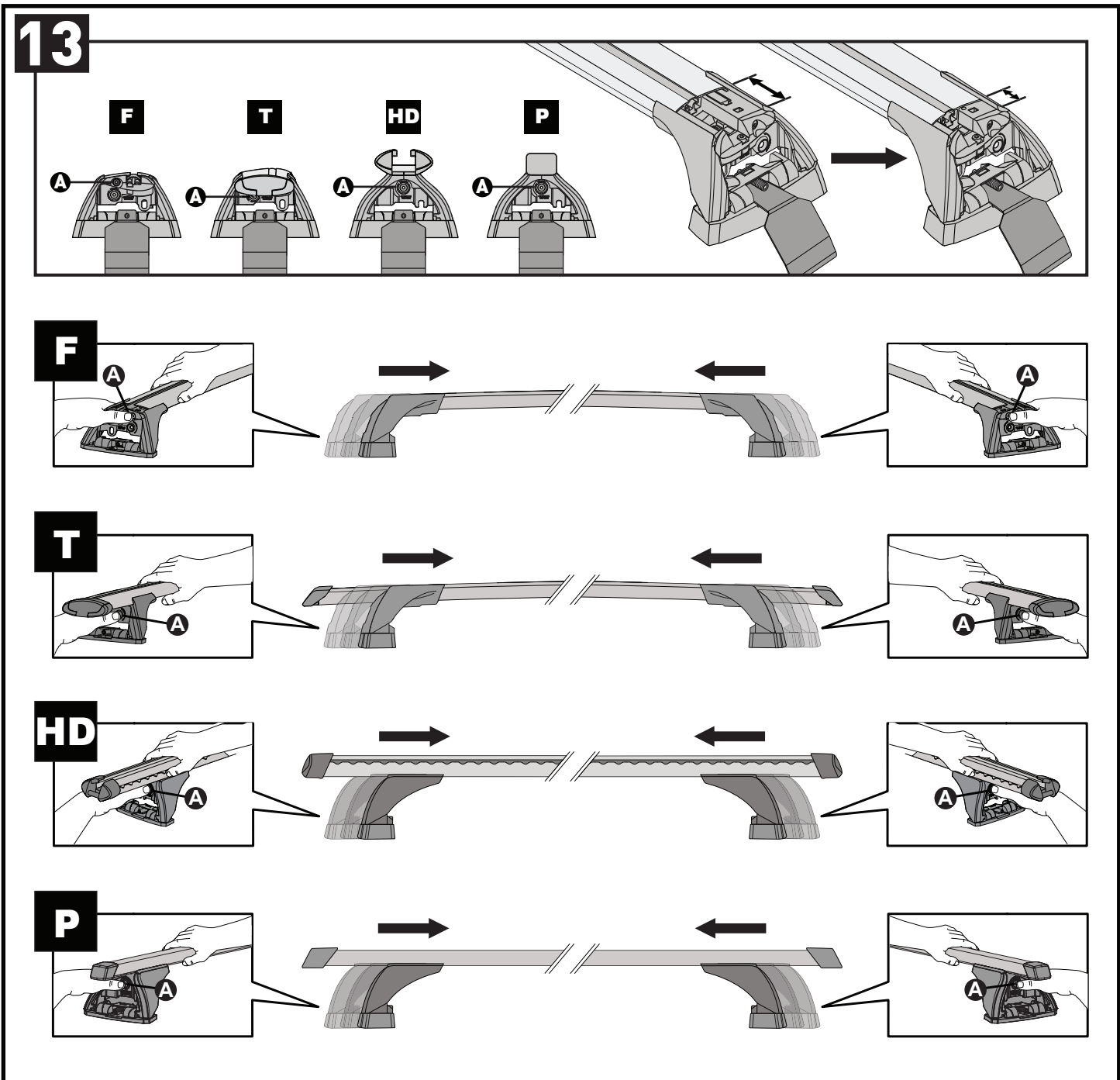
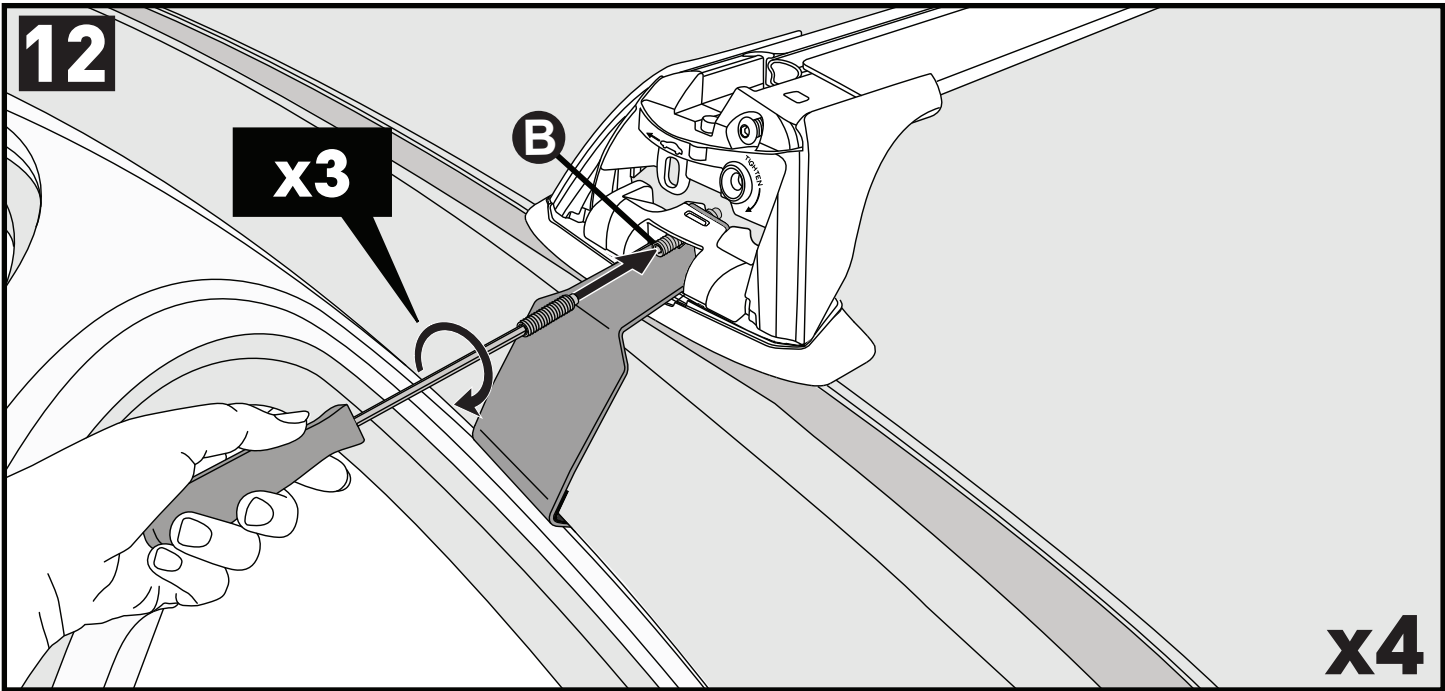

CLOSE • GESCHLOSSEN • CERRAR • FERMER • LUKKE • FECHAR • ЗАКРЫТЬ • CHIUDERE • BLISKO ZAVŘÍT • ZAVRIĚT • GESLOTEN • STÄNGA • LUK • ЗАКРИТИ • SULKEA

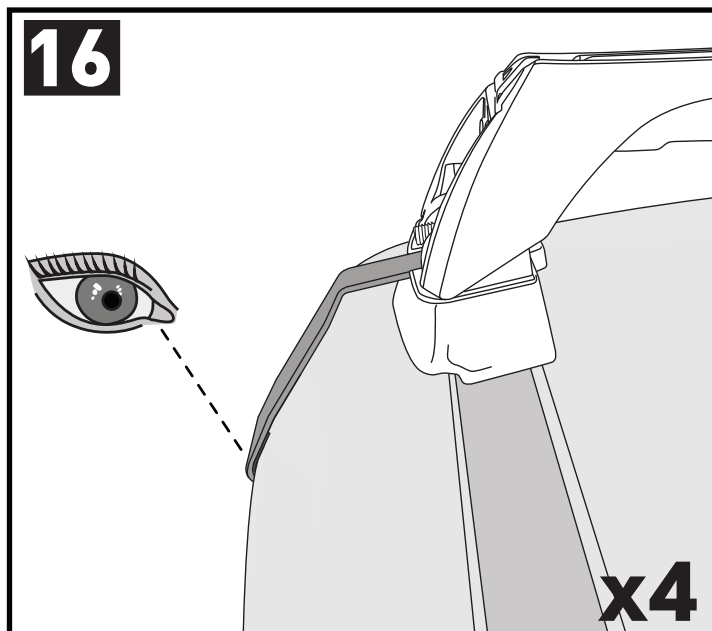
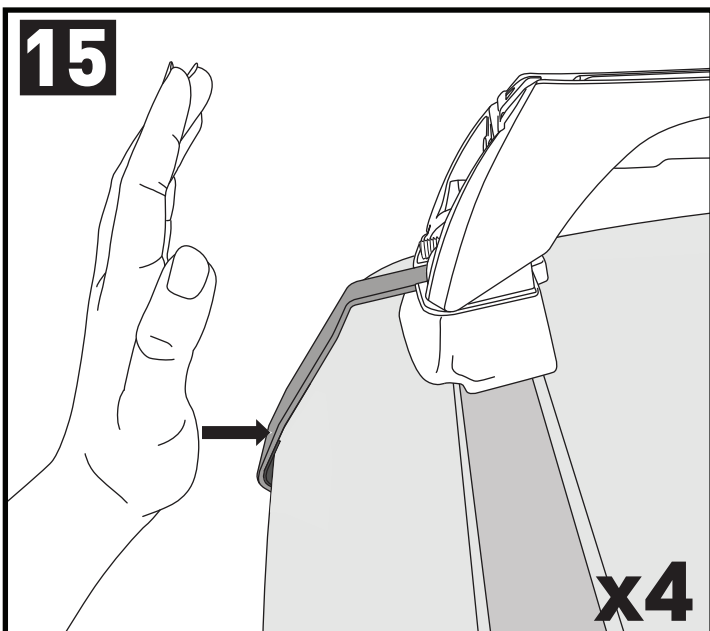
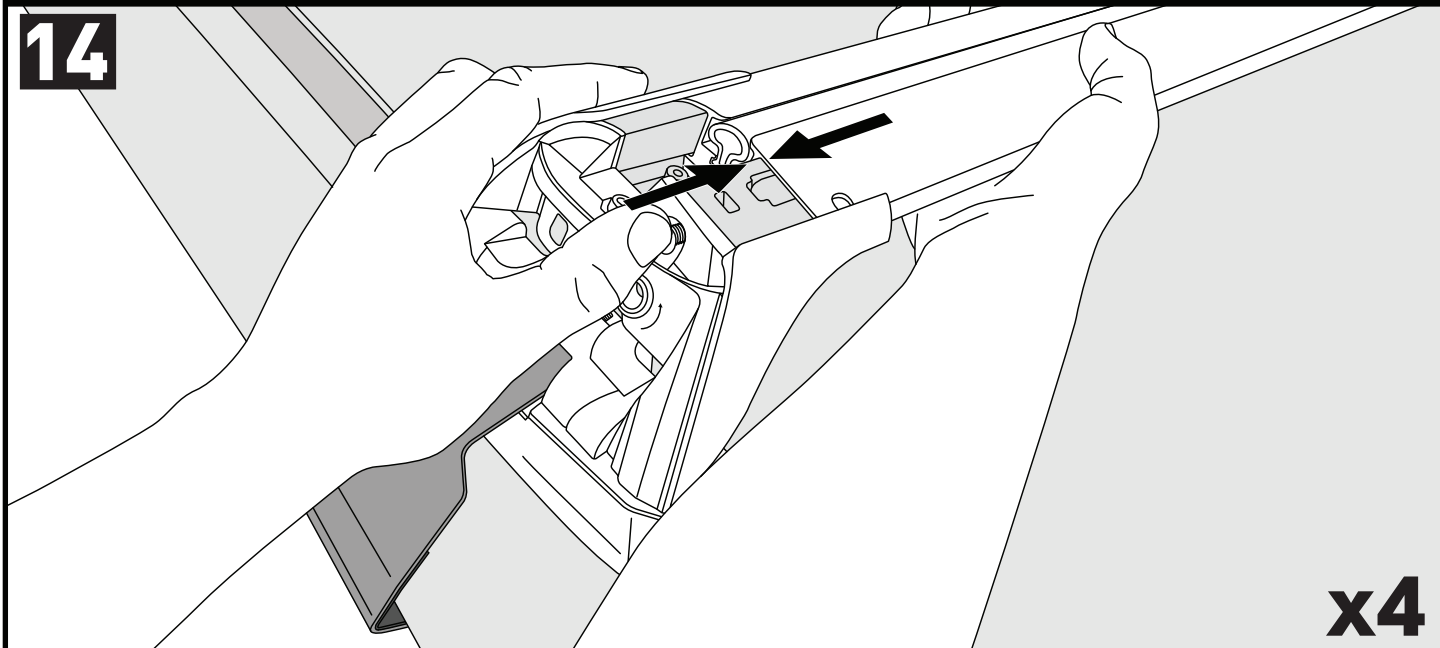

ATTENTION • ACHTUNG • ATENCIÓN • ATTENTION • OPPMERKSOMHET • ATENÇÃO • ВНИМАНИЕ • ATTENZIONE UWAGA • UPOZORNĚNÍ • UPOZORNENIE • LET OP • UPPMÄRKSAMHET • OPMÆRKSOMHED • УВАГА • HUOMIO

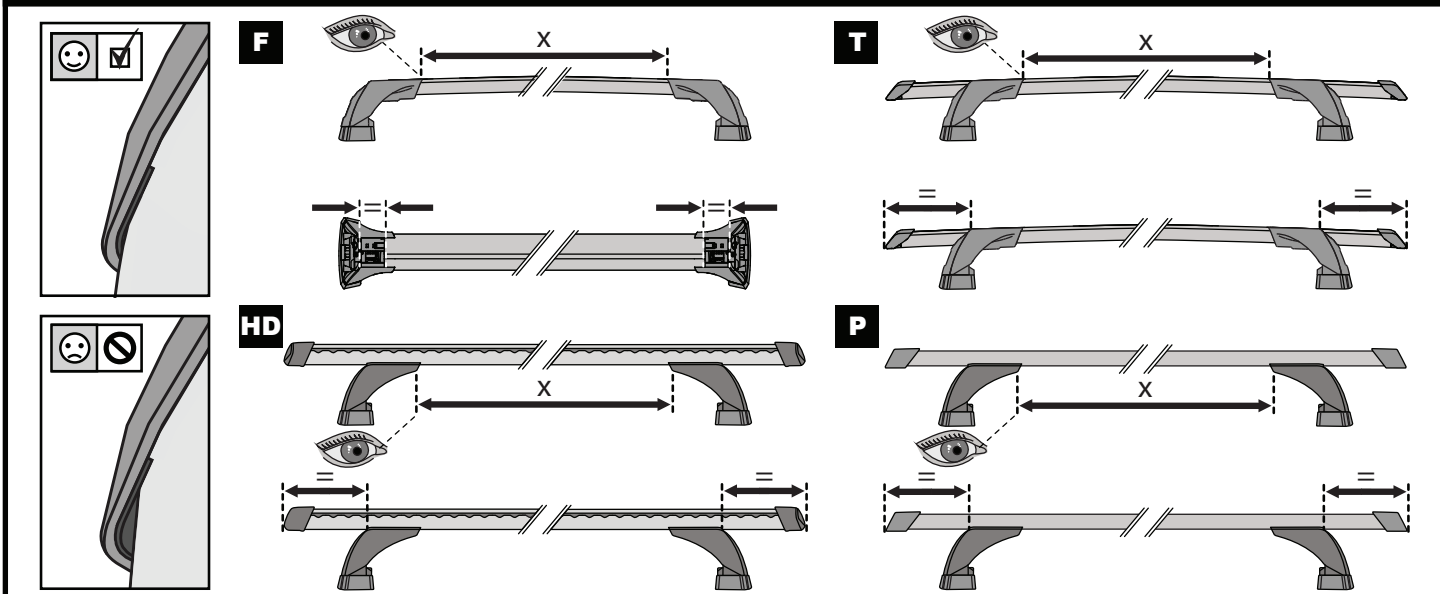

17

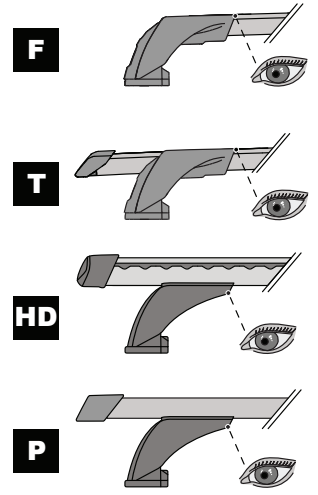
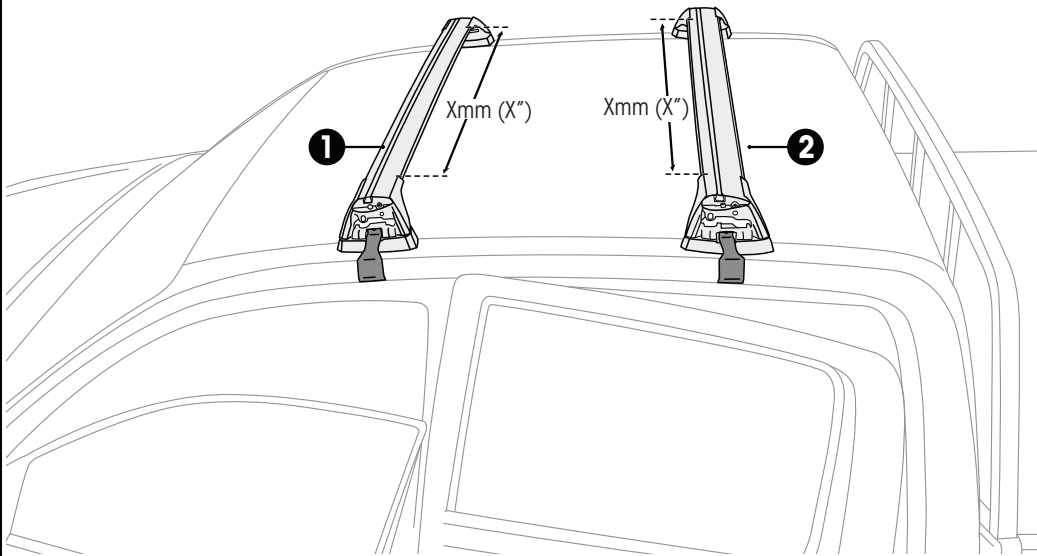

		1	2
Toyota Hilux Single Cab, 2dr Ute 05-11	EU, CN, ZA	X = 863 mm (34")	-
Toyota Hilux Single Cab, 2dr Ute May 05-11	AU, NZ	X = 863 mm (34")	-
Toyota Hilux Xtra Cab, 2dr Ute 04+	EU, CN	X = 863 mm (34")	X = 852 mm (33 1/2")
Toyota Hilux Xtra Cab, 2dr Ute May 05-Oct 15	AU, NZ	X = 863 mm (34")	X = 852 mm (33 1/2")

18

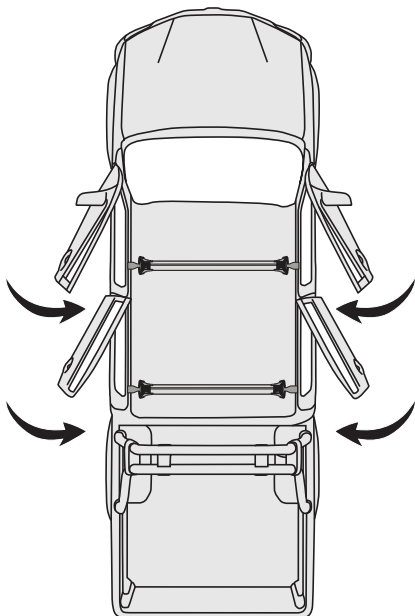

19

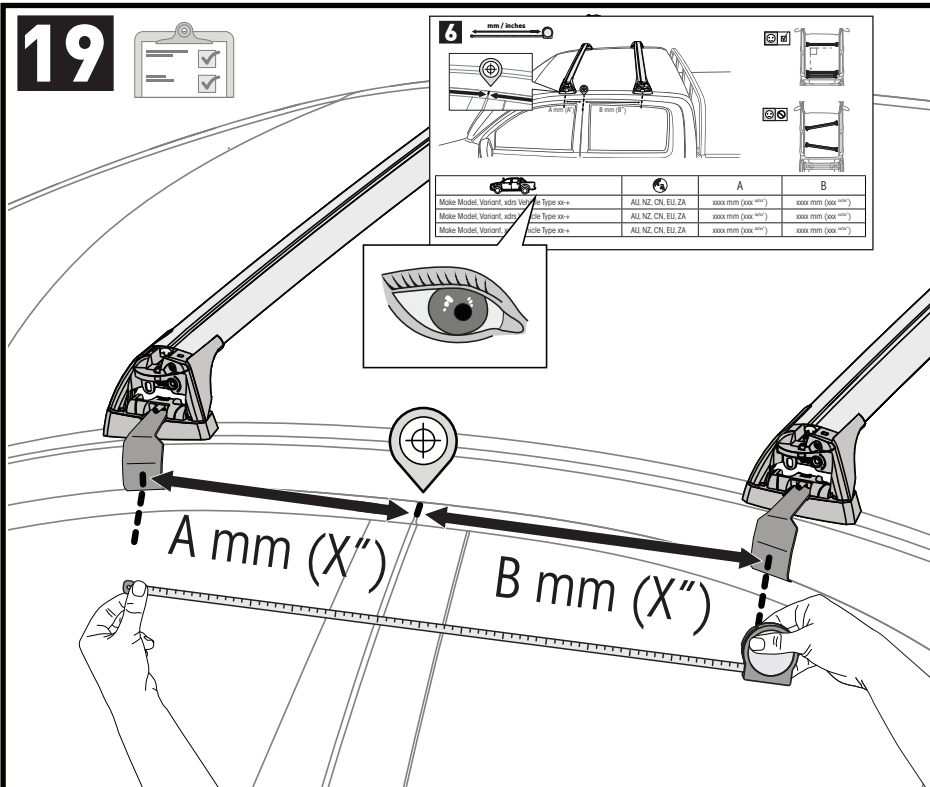

20

F

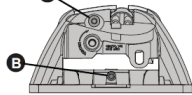

T

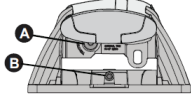

HD

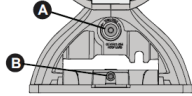

P

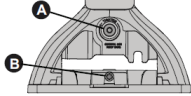

**2 Nm
(18 lb-in)**

A

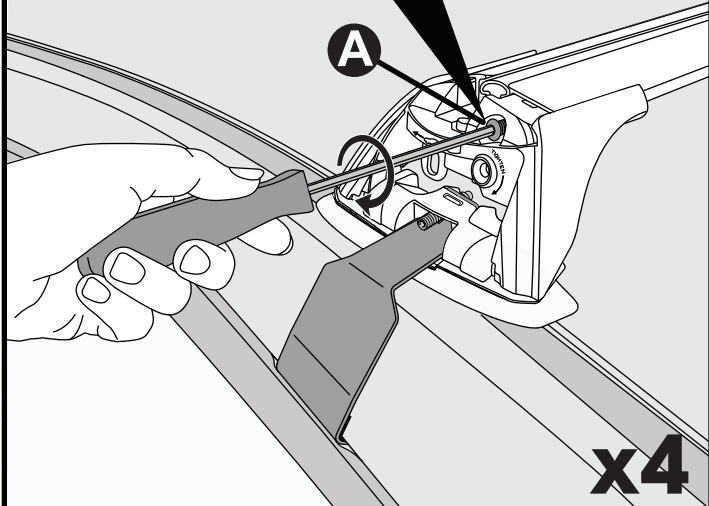

x4

21

**2.5 Nm
(22 lb-in)**

B

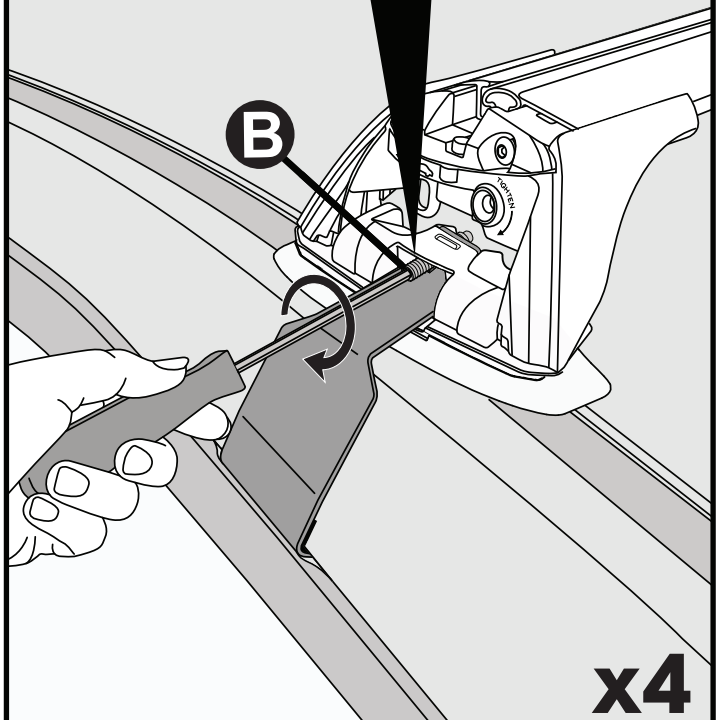

x4

22

F

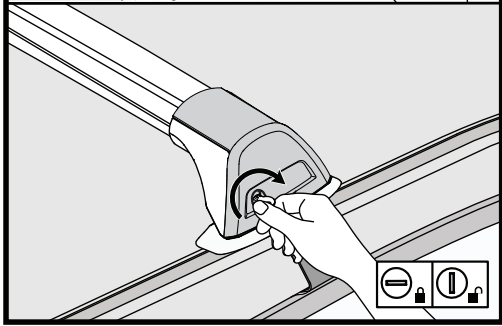
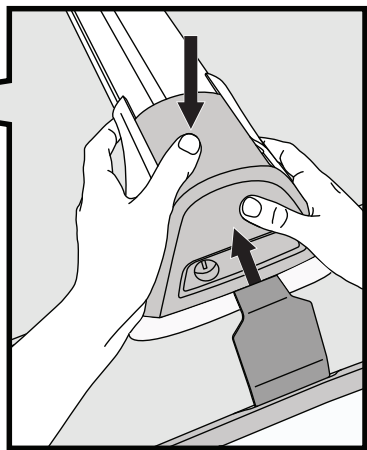
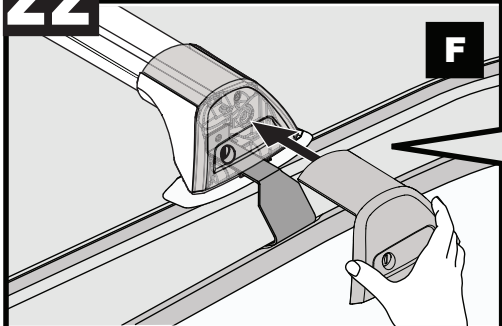

T HD P

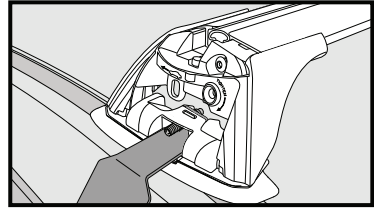
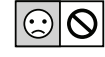
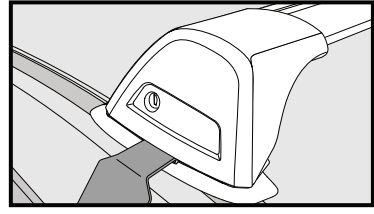
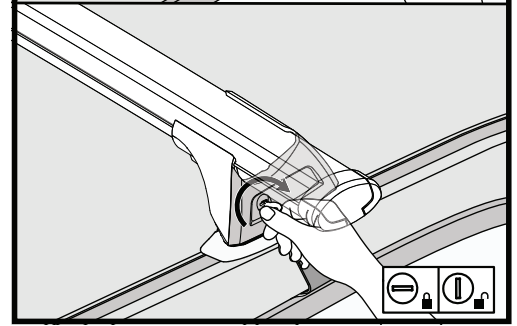
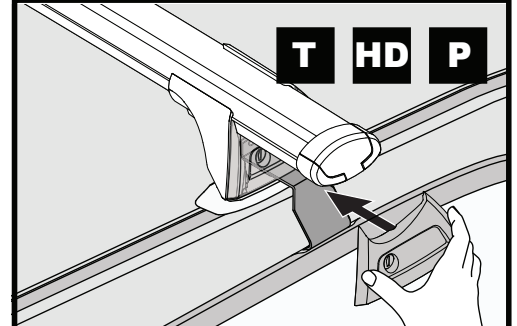

x4

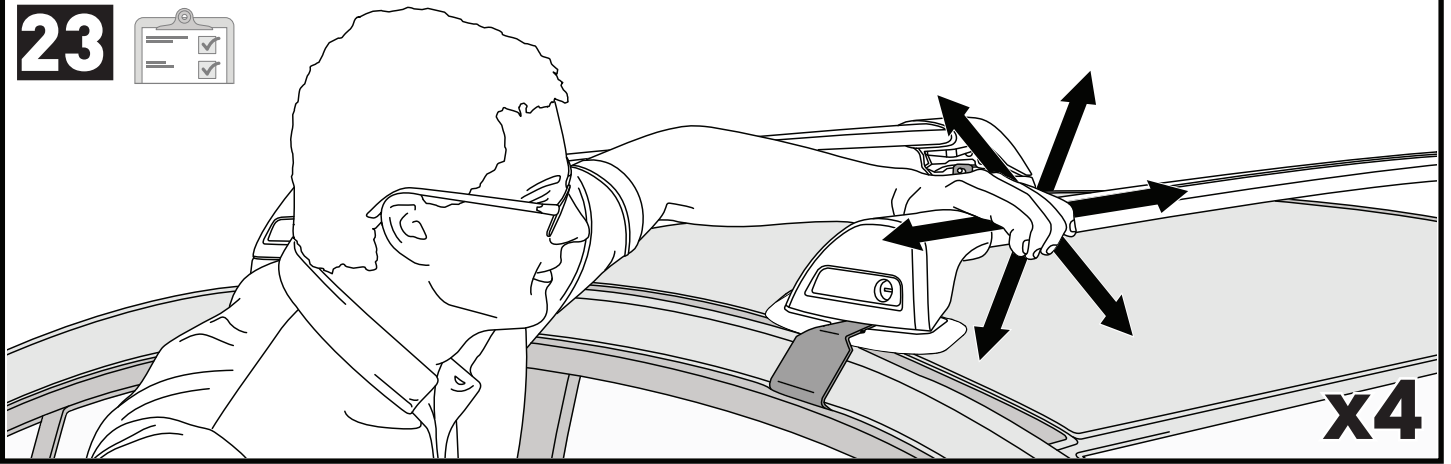
23

**ATTENTION • ACHTUNG • ATENCIÓN • ATTENTION • OPPMERKSOMHET • ATENÇÃO • ВНИМАНИЕ • ATTENZIONE
UWAGA • UPOZORNĚNÍ • UPOZORNENIE • LET OP • UPPMÄRKSAMHET • OPMÆRKSOMHED • УВАГА • HUOMIO**

EN Please read safety and warranty booklet included with this product prior to use. For more information visit your local dealer.

DE Bitte lesen und beachten Sie die beiliegende Montageanleitung, Sicherheitshinweise und Garantiebedingungen bevor Sie das Produkt montieren/benutzen. Für weitere Informationen kontaktieren Sie bitte Ihren Händler.

ES Por favor, lea folleto de seguridad y garantía que se incluye con este producto antes de su uso. Para obtener más información, visite a su distribuidor local.

FR Veuillez lire attentivement le manuel de sécurité et de garantie avant utilisation. Pour plus d'informations, visitez votre concessionnaire local.

NO Vennligst les hefte om sikkerhet og garanti som er vedlagt dette produkt før det tas i bruk. For mer informasjon ta kontakt med din forhandler.

PT Por favor leia o manual de segurança e garantia incluído, antes de utilizar o produto. Para mais informações visite o seu revendedor local.

RU Пожалуйста, ознакомьтесь с инструкцией перед тем, как использовать товар. Для получения более подробной информации обратитесь к местному дилеру.

IT Si prega di leggere il libretto di sicurezza e garanzia incluso nel prodotto prima dell'uso. Per maggiori informazioni visita il rivenditore locale.

PL Proszę zapoznać się z warunkami gwarancji i bezpieczeństwa przed użyciem produktu. W celu uzyskania dodatkowych informacji proszę kontaktować się z najbliższym autoryzowanym punktem sprzedaży.

CS Před použitím si prosím přečtěte přiložené informace o bezpečnosti a záručních podmínkách. Pro více informací navštivte nejbližšího dealera.

SK Pred použitím si prosím prečítajte priložené informácie o bezpečnosti a záručných podmienkach. Pre viac informácií navštívte najbližšieho diera.

NL A.U.B. bijgesloten garantie- en veiligheidsinstructies grondig lezen voor gebruik van dit product. Voor meer informatie graag contact opnemen met uw dealer.

SV Var snabb och läs igenom säkerhets- och garantihäftet som medföljer produkten före användning. För mer information besök din lokala återförsäljare.

DK Læs venligst sikkerheds- og garantibogholderen, der følger med dette produkt, inden brug. For mere information besøg din lokale forhandler.

UA Будь ласка, ознайомтеся з броюньо безпеки та гарантії, включені до цього продукту перед використанням. Для отримання додаткової інформації відвідайте місцевого дилера.

FI Lue tämän tuotteen mukana toimitetut turvallisuus- ja takuu huoltopalvelut ennen käyttöä. Lisätietoja saat paikalliselta jälleenmyyjältä.

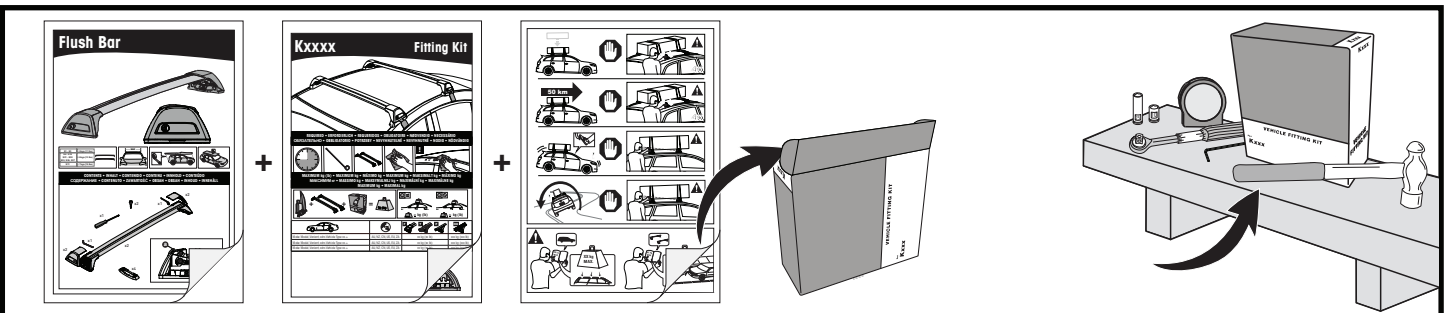
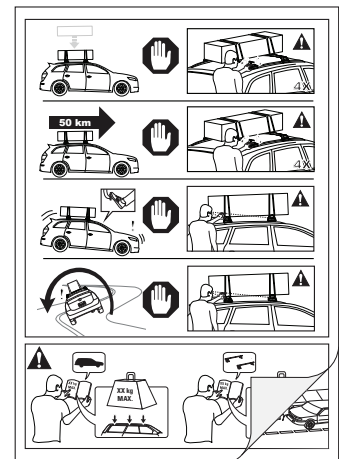

Yakima Australia Pty Ltd
17 Hinkler Court, Brendale
QLD 4500, Australia
1800 143 548
www.prorack.com.au
www.whispbar.com.au
www.yakima.com.au

Yakima Products, Inc.
4101 Kruse Way
Lake Oswego, OR. 97035 USA
888 925 4621
www.yakima.com

WORKS WITH:

